



CONTRACTOR ◇ CONNECTION

Taking My Hacks



A message from Jackson Lumber & Millwork President, Mark Torrisi

Last year felt like we were finally getting back to a sense of normalcy, at least as far as the lumber market is concerned.

We saw prices stay fairly stable, with much smaller fluctuations than we experienced in the previous two years. With 2023 now sitting in the rearview mirror, I want to share my thoughts on where I think 2024 will take us.

As for the lumber market, the price forecast for the beginning of 2024 looks very similar to the pricing we saw throughout 2023, fluctuating within a relatively narrow range.

However, we are closely watching the forecasts for continued heavy curtailment out in Western Canada. That will be offset by additional production coming out of the U.S. South.

What does that mean for us? Western SPF will become harder to source, and prices will probably rise. That is usually where we get most of our 2x10 and 2x12

"As for the lumber market, the price forecast for the beginning of 2024 looks very similar to the pricing we saw throughout 2023."

framing material. We have secured contracts for consistent supply from various mills throughout the year, so we should be in a good position.

Long term, we might have to start looking for alternatives to western SPF, which could include I-joists or using southern yellow pine for floor joist or rafters.

I am not expecting this to happen in the next few years, but it could happen sometime in the future. We will keep an eye on this and keep you informed as things change.

As for the economy, I expect things to improve as the year progresses. Projections for the second half of the year call for some relief from the soaring interest rates that stifled the U.S. housing market and overall economy for much of 2023.

Single family housing starts are forecasted to rise by 4% this year. On the downside, multi-family housing starts are expected to fall anywhere from 25% to 40%. Lower interest rates should also have a positive impact on renovation and remodeling projects.

Our goal here at Jackson Lumber & Millwork is to provide you with the best possible service and value, so please do not hesitate to contact any of our team members to help you with your projects. Thank you again for giving us the opportunity to serve you. Your business is greatly appreciated.

mtorrisi@jacksonlumber.com

Product Showcase

Jackson Lumber & Millwork is Now Stocking Exterior Door Frame Components for 7-5/8" Wall.

Exterior Wall Depth Change

In order to adapt to new stretch code requirements in Massachusetts and New Hampshire, many wall systems are migrating to wall panels with built-in insulation that integrates moisture, air, and thermal protection. As a result, the exterior wall depth changes to 7-5/8" when utilizing Huber R6 Zip Insulated R-Sheathing.

Home Energy Rating System

By integrating performance testing, building materials, HVAC equipment, appliances, and lighting, the Home Energy Rating System (HERS) provides a holistic view of the energy usage of the home.

When it comes to building materials, how does a HERS rating work? It looks at an array of building materials used in the home and calculates the impact each component will have on the HERS score.

Insulation type, depth, and quality of installation are all documented to calculate the



R-Value of the walls, floors, and ceilings of the home.

Window performance ratings show the insulation factor, U-Value, and how much solar energy radiates through the glass – the solar heat gain coefficient (SHGC).

Additional factors, including the framing factor of walls or radiant barriers on roofs, are also documented and entered into the HERS rating software.

For more information about our new component options for 7-5/8" wall depth please contact your Jackson sales representative.

Continued on Page 2

Inside this issue:

Exterior Door Components	2
<i>Cont'd from Pg. 1</i>	
Sales Team News	2
Events	2, 3
JLM Photo Album	2

Pricing Matrix	3
<i>Framing Lumber & Materials</i>	
Employee Spotlight	3
Vendor Spotlight	4



JLM Sales Team News

2023 Sales Team Awards Announced

Congratulations to the top sales performers of 2023 for Jackson Lumber & Millwork and Jackson Kitchen Designs.

Kudos to all, and many thanks to our entire team of sales professionals and designers for their hard work and dedication.



Ern Villers Jr.



Derek Hurrell



Russ Zimmermann



Mike Curran



John McQuinn



Ian Vosgien

Jackson Kitchen Designs

Top Sales Performers:
Lucy Ross,
Jessica Sykora



Lucy Ross



Jessica Sykora

Jackson Lumber & Millwork

DL30 Cup Winner:
John McQuinn
Evergreen Award:
Ern Villers Jr.

Spruce Awards:
Mike Curran,
Derek Hurrell,
Ian Vosgien,
Russ Zimmermann

Product Showcase

Exterior Door Frame Component Options for 7-5/8" Wall.

Continued from Page 1.



PRIMED COMPOSITE JAMB & HEAD JAMB

PRIMED COMPOSITE PRODUCT CODES	
758TTSIDPRCOMP	7-5/8 X 6/8 PRIMED COMPOSITE JAMB
758TTHDPRCOMP	7-5/8 X 3/0 PRIMED COMPOSITE HEAD JAMB

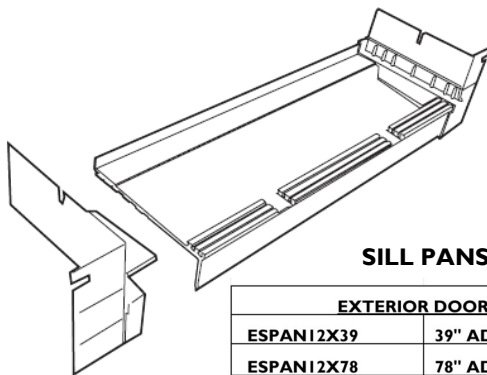

For more information about our new component options for 7-5/8" wall depth please contact your Jackson sales representative.

SILL PANS for EXTERIOR DOORS

EXTERIOR DOOR SILL PANS PRODUCT CODES	
ESPAN12X39	39" ADJUSTABLE SILL PAN UP TO 8-5/8" WALL
ESPAN12X78	78" ADJUSTABLE SILL PAN UP TO 8-5/8" WALL

SELF ADJUSTING SILLS

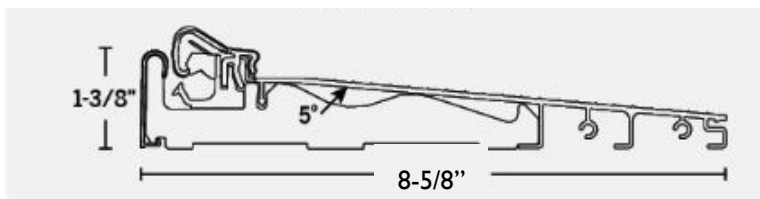

SELF ADJUSTING SILLS PRODUCT CODES	
ZAC86DMFN103010	Z-SERIES 1/0 X 3/0 X 1/0 X 8-5/8" SELF ADJUSTABLE SILL
ZAC86DMFN30	Z-SERIES 3/0 X 8-5/8" SELF ADJUSTABLE SILL

Events

Save the Dates!

You are invited to come to our Spring Contractor Breakfasts.

No reservations needed!

Stop by for a hot breakfast sandwich and a cup of coffee if you are in the area in that morning. We hope you can join us!



Photos from our Spring 2023 breakfast in Woburn.

Spring Contractor Breakfast Schedule:

LAWRENCE STORE
Thursday, April 4th

RAYMOND STORE
Thursday, April 11th

AMESBURY STORE
Thursday, APRIL 18th

WOBURN STORE
Thursday, April 25th

Events Continued on Page 3

JLM Photo Album



A beautiful aerial view of our Raymond, NH facility taken in the Fall of 2023.

Events

Continued from Page 2.

You Are Invited!

Be our guest at JLC LIVE 2024, the largest event

in New England for builders, remodelers, contractors, and their crews.

Your Admission, Transportation & Lunch Are On Us!

Build Your Knowledge & Perfect Your Skills.
See the Hottest Products.

Learn the Newest Building Techniques.

JLCLIVE'24

RESIDENTIAL CONSTRUCTION SHOW

**Friday, March 22nd
Providence, RI
Convention Center**

- ▶ 300 Building Products Manufacturers.
- ▶ TWO Expo Halls.
- ▶ LIVE Exhibitor Demos.
- ▶ LIVE Installation & Building Clinics.

Reserve your admission ticket and seat on the bus at any Jackson Lumber & Millwork lumber counter.



**Reservation deadline:
Friday, February 23**



Schedule:
Buses depart from the Amesbury & Lawrence stores in the early morning. Exact time TBD. Lunch will

be provided. Return bus leaves the RI Convention Center at 2:30 p.m.



Pricing Matrix

Stay on top of market pricing trends for Framing



MONTHLY COST INDEX FOR FRAMING LUMBER & MATERIALS

36x24 House with a 20x20 Attached Garage (2,128 Sq. Ft.) All quotes include taxes.

ECONOMY PRICE PER SQUARE ▶ QUOTE #177933

Includes: 2x6 Exterior Walls, 7/16 OSB Wall Sheathing and 1/2 Fir Roof Sheathing, 3/4" T&G OSB, Stick Framed Floor and Roof System, Double 4" Vinyl Siding, IKO Shingles and Roofing Components, Nails and Hangers.

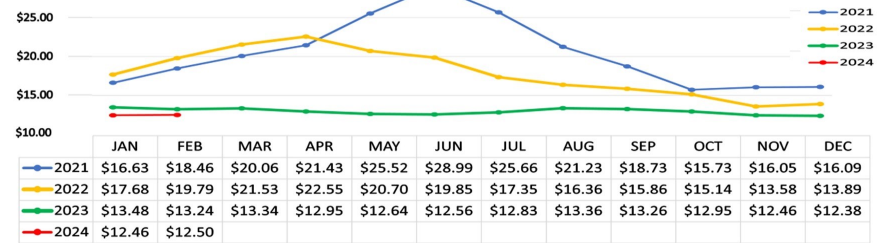

PREMIUM PRICE PER SQUARE ▶ QUOTE #420409

Includes: 2x6 Exterior Walls, 1/2" Zipwall & 5/8" Ziproof, Advantech Subfloor, Stick Framed Floor and Roof System, 5-1/4" Color Plus Hardie Siding, PVC Exterior Trim, IKO Cambridge Shingles and Roofing Components, Nails and Hangers.

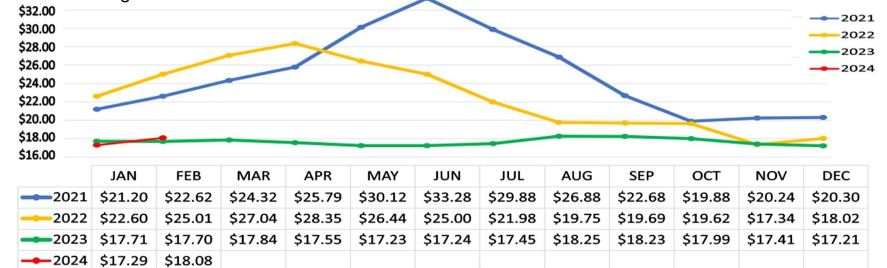

PREMIUM PLUS PRICE PER SQUARE ▶ QUOTE #177944

Includes: The same specs as the premium price spec, however the floor joists are upgraded to an I Joist System.

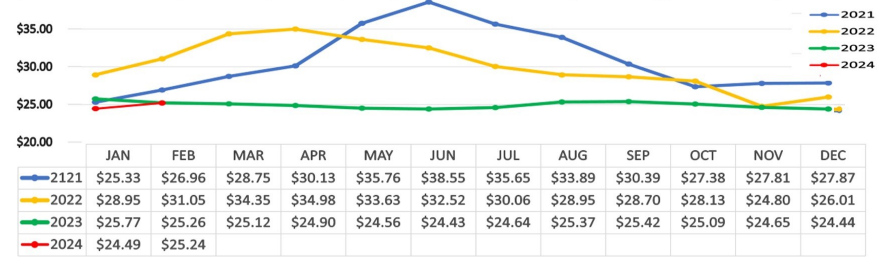

These quotes represent current market prices and can only be used as a rough budget quote with the standard of the industry building practices. They do not include Windows, Doors, Decks, Porches, or Interior Finishes.

JLM Employee Spotlight

Janet Maglia

Kitchen Designer
North Andover

A versatile, skilled, and talented designer, Janet Maglia has been an integral part of the Jackson Kitchen Designs team for 26 years.

The U-Mass Lowell Business Administration major started with Jackson as a receptionist in 1998 but soon became interested in learning the design aspect of the business. She took many courses with the National Kitchen and Bath Association (NKBA) and attended classes

with various manufacturers to learn about their products. Armed with this training, Janet became a kitchen designer less than two years after joining the company.

A real people person, Janet loves working with clients to transform their existing kitchen, bath, or office into a more functional and beautiful space. She likes helping clients make cabinetry, countertop, and hardware selections that reflect their own unique style and taste.

What does the future hold? Janet plans to continue working as a designer but in the

future, she might want to semi-retire and travel more frequently. Besides traveling, Janet enjoys cooking, reading, walks on the beach, spending time with family and friends, and playing 45's.

Janet loves spending time with her fiancé Steve, her son Thomas and wife Cece, and son Michael and wife Elyse, but her pride and joy is her 10-month-old grandson Leo, who she just can't get enough of!

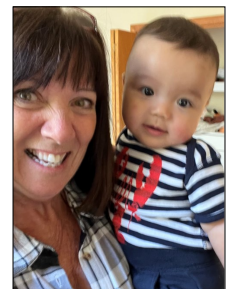

Janet Maglia & grandson Leo.



Jackson LUMBER & MILLWORK

Jacksonlumber.com

5 CONVENIENT LOCATIONS:

AMESBURY, MA
67 Haverhill Rd.
Phone: 978-388-0366
Mon-Fri: 6:30 a.m. - 4:30 p.m.
Sat: 7:00 a.m. - 12:00 p.m.

LAWRENCE, MA
215 Market St.
Phone: 978-686-4141
Mon-Fri: 6:30 a.m. - 4:30 p.m.
Sat: 7:00 a.m. - 12:00 p.m.

RAYMOND, NH
10 Industrial Dr.
Phone: 603-895-5151
Mon-Fri: 6:30 a.m. - 4:00 p.m.

WOBURN, MA
10 Jefferson Ave.
Phone: 781-933-0057
Mon-Fri: 6:30 a.m. - 4:30 p.m.
Sat: 7:00 a.m. - 12:00 p.m.

**JACKSON KITCHEN
DESIGNS
NORTH ANDOVER, MA**
Butcher Boy Marketplace
1093 Osgood St. (Rt. 125)
Phone: 978-685-7770
Mon: 9:00 a.m. - 3:00 p.m.
Tues-Fri: 9:00 a.m. - 5:00 p.m.
Sat: 9:00 a.m. - 3:00 p.m.
Appointments available



JLM Vendor Spotlight

Woodgrain

Headquarters:
Woodgrain Distribution—Lawrenceville, GA
Woodgrain Millwork—Fruitland, ID

Quality Craftsmanship Meets Superior Performance.

One of the largest millwork operations in the world, Woodgrain is a vertically integrated wood manufacturer and distributor specializing in lumber, mouldings, doors, and windows.

Proud to be family owned and operated for over 65 years, Woodgrain was founded by Bud Dame in 1954, and continues to grow under the third generation of Dame family leadership. Their core values drive Woodgrain's success - safety, integrity, servant leadership, respect, and customer focus. These values are the crux of Woodgrain's overall mission to leverage vertical integration to deliver specialized solutions and building products at premier service levels. The way employees are treated instills pride in themselves, their company, and the customers served.

Vertical Integration

Woodgrain owns their supply chain, which is rare in this industry. They own the forest that they cut and process their lumber from, as well as the facilities that manufacture their mouldings and the parts that are used for their doors and windows. They own each step in the supply chain, which ensures complete oversight of the quality of wood they process and the finished parts they produce. Because Woodgrain owns their own trucks and distribution, they are not dependent on industry shifts or controlled by outside environments, which means they can ensure quality control and efficient delivery times, every time.

Woodgrain & Huttig

In 2022, Woodgrain acquired Huttig Building Products, one of the largest distributors of millwork, building materials, and wood products. This move significantly increased Woodgrain's product offerings with a range of value-added services and a more robust vertical integration strategy. Woodgrain now offers a coast-to-coast distribution network and a wide variety of products that cater to diverse needs and preferences while always maintaining the quality of their products.



Woodgrain & Jackson

The Woodgrain go-to-market strategy is to increase exposure for all vendor partners through continuing education, display and sample placement, field product support, and customer engagement events. Jackson Lumber & Millwork counts on Woodgrain as a distribution partner for these premium products and brands: AZEK TimberTech Deck, Rail, and Trim, HB&G Columns, Maibec Cedar Shingles, PlyGem Vinyl Siding, GRACE and env-s by GCP, Simpson Strong-tie, Thermo-Tru Exterior Doors, and Masonite Interior Doors.

Trending Products

The market trends that Woodgrain sees for 2024 are minimalistic design, outdoor living as a growth category, mixed-mediums on siding, and pre-finished products for low-maintenance and sustainability.



As a market leader in the outdoor living category, Woodgrain is the only distributor committed to the full AZEK EXTERIOR ENVELOP – Shingle Panels, Bevel Siding, Board & Batten, Deck, Railing, and White and Pre-Finished Trim.



Therma-Tru exterior doors are the 'doorway' to a beautiful outdoor environment. The new Veris line is a premium collection of expansive aluminum glass doors offering a seamless transition to any outdoor living space. Our local Woodgrain branch is a pre-finish facility for PrismaGuard painted Thermo-Tru doors.



The premier name in pre-finished Eastern White Cedar Shingles, Maibec now offers custom pre-finished Western Red Cedar Shingles. If you are looking for the best of the best, look no further!



Woodgrain is a full-source provider of exterior siding. Create a dynamic siding presentation with Silvermine Stone, the original mortarless stone veneer with built-in flashing, and PlyGem vinyl lap siding and board and batten accents.



woodgrain